

GPN9

Peak Torque **300 Ncm**
 Cont. Torque **30 Ncm**
 Cont. Power **94 Watts**
 Speed **<1 to 6000 rpm**

The Printed Motor Works GPN12 is a totally enclosed dc motor in an ultra slim pancake profile. This pancake motor utilizes high power 'rare earth' magnets and can provide, higher performance, yet cost effective servo capability. Using flat armature technology the motor is ideal for general purpose applications.



GPN9

Motor Constants	Symbol	Unit	Value
Voltage	Ke	V/krpm	5.0
Torque	Kt	Ncm/Amp	4.8
Damping	Kd	Ncm/1000rpm	0.50
Friction	Tf	Ncm	1.2
Terminal Resistance	I	Ohm	1.1

Motor Ratings	Unit	Value
Voltage	Volts	22.5
Current	Amps	6.9
Torque	Ncm	30.0
Speed	RPM	3000
Power	Watts	94

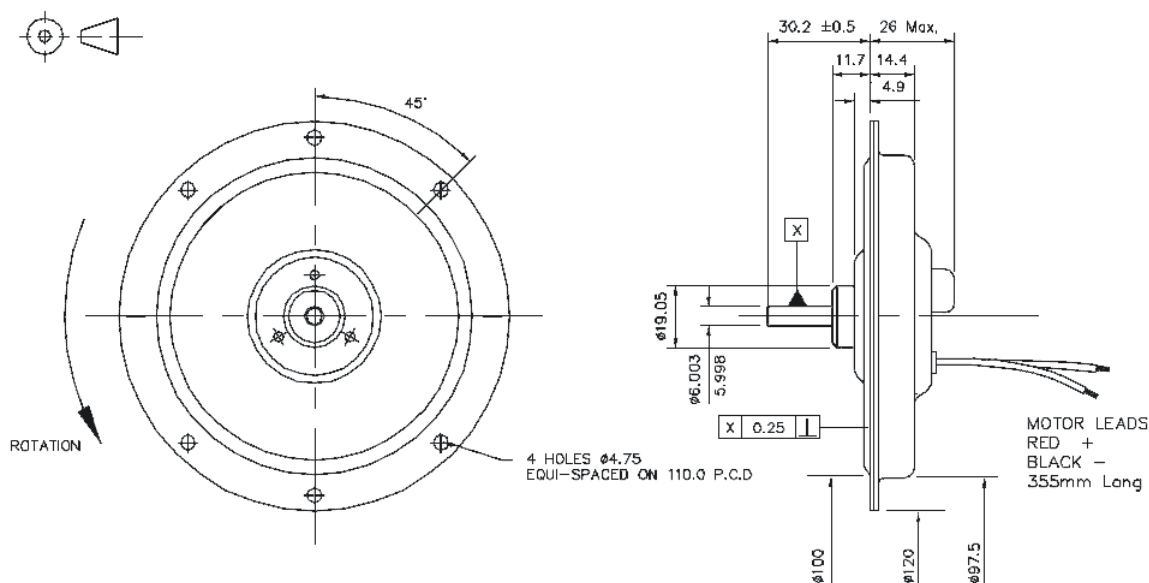

Sample design modifications

Shaft

- Round shaft
- Extra flats
- Length variants
- Cut gear
- Other modifications

Brushes

- Long life for continuous duty applications
- Low resistance brushes for servo applications
- High altitude
- Vacuum

Extra

- EMC suppression
- Long leads
- Connectors
- Tri-rated cable
- Use in low ambient temperatures



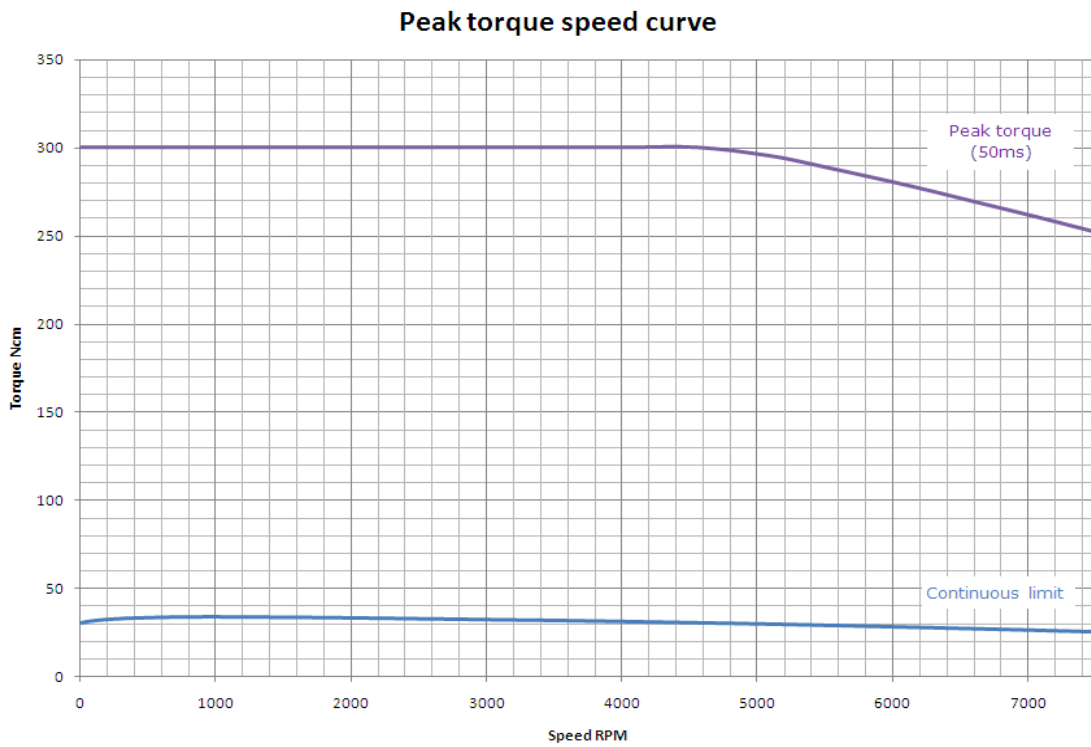
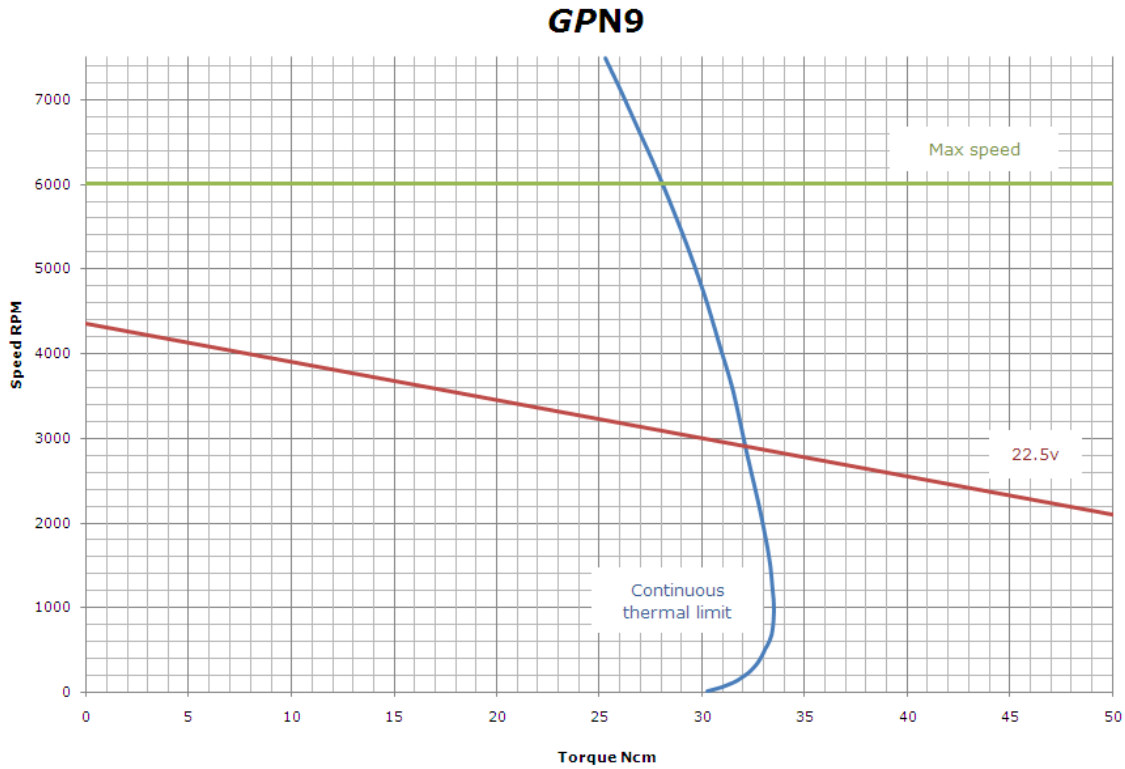

NOTE: The angle of the Torque/Speed curve remains the same for higher and lower voltages. The speed varies proportionally from zero rpm relative to the voltage supplied. The stated voltage is an example, not a predefined maximum or minimum. Due to ongoing product improvement data in this datasheet maybe subject to change without notice.

