

GP LR Series

Peak Torque **100 to 1000 Ncm**
 Cont. Torque **10 to 100 Ncm**
 Power **38 to 324 Watts**
 Speed **<1 to 6000 rpm**

The Printed Motor Works GP LR series is a totally enclosed dc motor in an ultra slim pancake profile designed specifically for low voltage and battery applications. This pancake motor can provide cost effective servo capability at lower voltages, compared with the standard GP series. Two variants of each size are available: one with a standard ferrite magnet (GPM) and the other with high-power neodymium magnets (GPN).

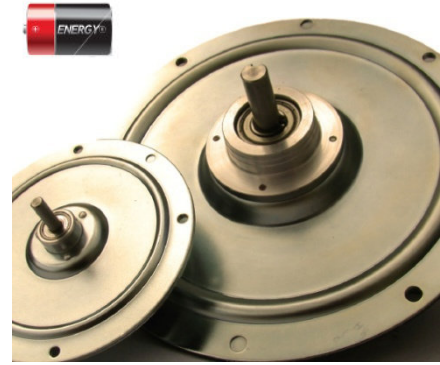

Motor Ratings	Symbol	Unit	GPM9LR	GPN9LR	GPM12LR	GPN12LR	GPM16LR	GPN16LR
Power	P	Watt	39	75	64	190	221	324
Torque	T	Ncm	10	25	20	48	73	100
Speed	N	rpm	3705	3887	3050	3810	2905	3102
Voltage	V	Volt	9	12	12	24	24	36
Current	I	Amp	11.7	11.4	10.8	11.0	13.4	11.7
Cont. Stall Current	IS	Amp	6.6	6.5	7	7	8	8

General benefits

- Specially designed for battery operation
- Low profile
- Zero cogging
- High instantaneous torque
- Rapid acceleration
- Low inertia
- Ultra slow/creep capability
- Wide speed range
- Low inductance
- Long brush life
- Excellent electromagnetic characteristics (EMC)
- Easily driven from a servo amplifier
- Design options for tachometer, encoder, gearbox, pulley, shaft, special performance tuning brushes.

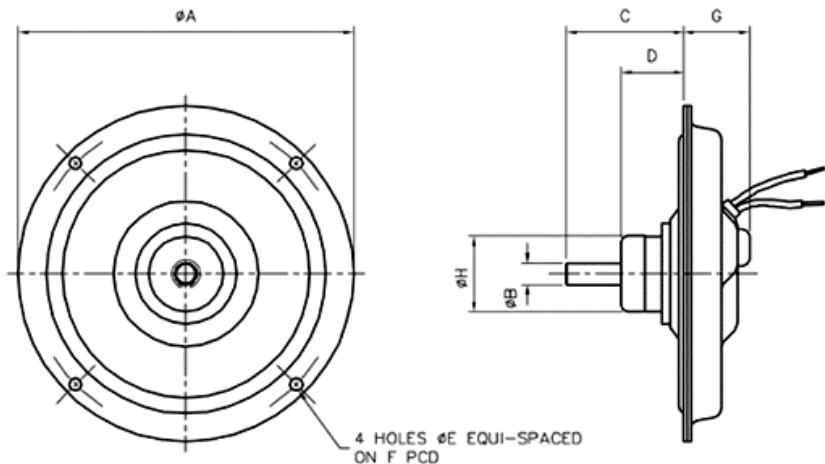

Motor type	Dimensions								Wt (Kg)
	A	B	C	D	E	F	G	H	
GPx9	120	6.003/5.998	30	11.7	4.7	110	26.0	19.05	0.59
GPx12	152	9.995/9.982	53	28.0	5.8	142	32.0	34.30	1.22
GPx16	215	11.988/11.976	60	32.5	7.1	200	35.6	45.72	2.90

Sample applications

Medical

Portable X-ray machines
 Blood centrifuges
 CT scanners

Industrial

Tensile Testing
 Metallurgical analysers
 Film processing
 Servo assisted brakes
 Paper handling

Marine

Auto pilots
 Wave generation



GP LR Series

GPM9LR

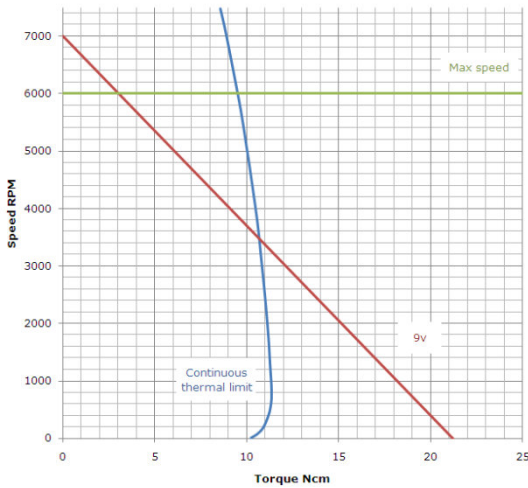

GPN9LR

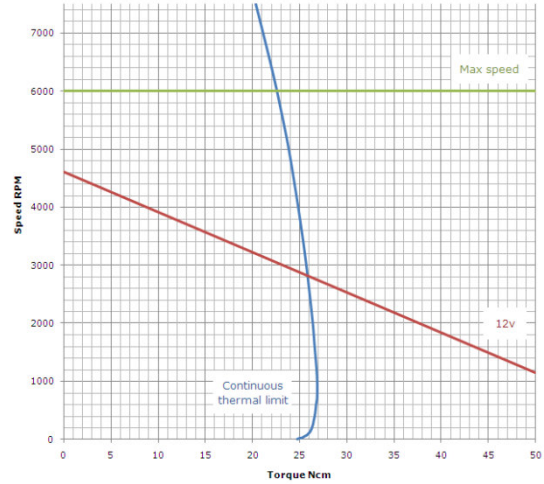

GPM12LR

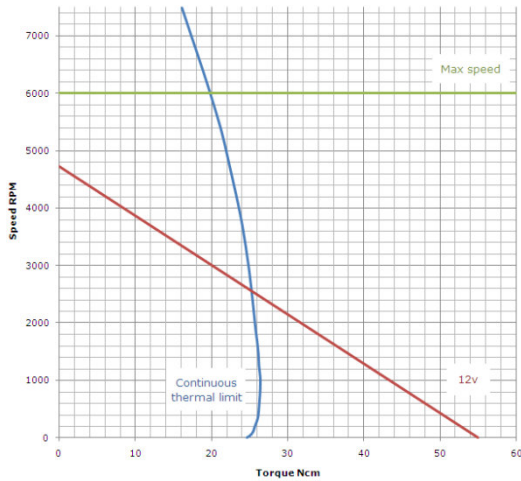

GPN12LR

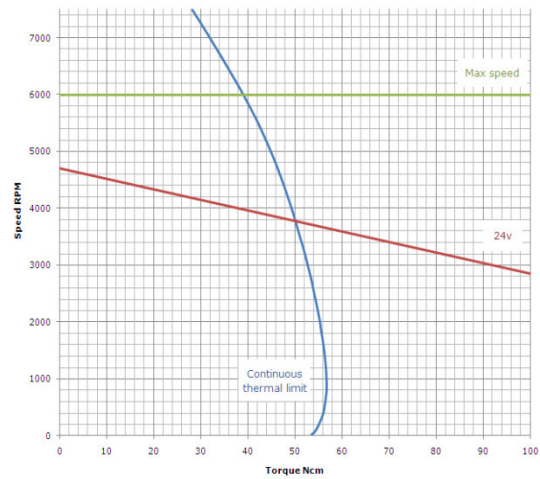

GPM16LR

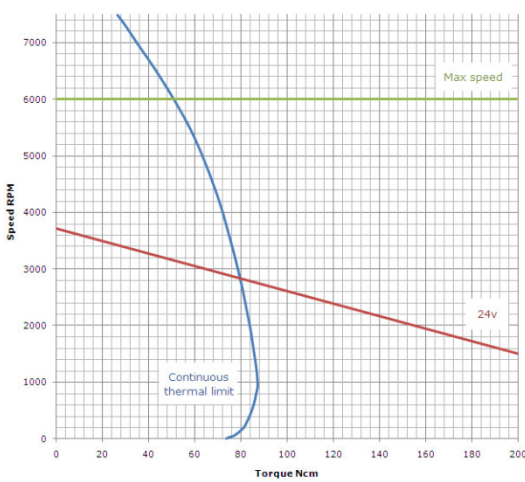

GPN16LR

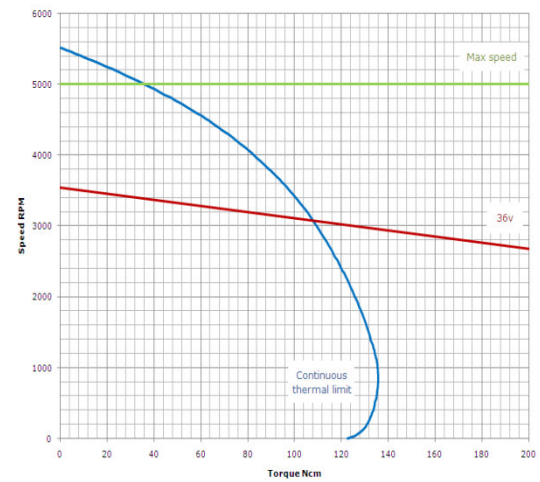

NOTE: The angle of the Torque/Speed curve remains the same for higher and lower voltages. The speed varies proportionally from zero rpm relative to the voltage supplied. The stated voltage is an example, not a predefined maximum or minimum. Due to ongoing product improvement data in this datasheet may be subject to change without notice.

